

**SANY**<sup>®</sup>

# SPR260C-8S PNEUMATIC TYRE ROLLER

## SPR260C-8S 轮胎压路机

### HYDRAULIC BRAKE SYSTEM

- ◆ Hydraulic all-wheel braking is engaged upon engine or transmission failure
- ◆ Braking distance is 50% less than similar equipment
- ◆ Transaxle brake is applied when the equipment stops without the need for hand brake

### AUTOMATIC INFLATION SYSTEM

- ◆ Tire pressure is adjustable from within the cab
- ◆ Even and consistent air pressure ensures compaction quality
- ◆ Air pressure is maintained even when a tire has a slow leak

### HYDRAULIC DRIVE SYSTEM

- ◆ Continuously variable drive system provides smooth starting and stopping
- ◆ Controls are easy to learn and easy to operate

### AUTOMATIC OIL-SPRAYING TECHNOLOGY

- ◆ Pneumatic powered automatic oil-spraying prevents asphalt from sticking to the tires
- ◆ Two minute suction refill of oil tank eliminates the manual refilling
- ◆ Eliminates the safety hazard of manually applying oil



#### 全液压驱动系统

- ◆ 无级变速，起停平稳，减小了对路面的冲击
- ◆ 操作简单，上手快，劳动强度小

#### 集中自动充气系统

- ◆ 自动充气，气压可调
- ◆ 气压均匀一致，压实平整
- ◆ 即使轮胎漏气也可正常持续施工

#### 卓越的压实能力

- ◆ 满足沥青路面，水稳基层等各种压实需要

#### 首创自动喷油技术

- ◆ 行业首创自动喷油技术，确保轮胎不粘沥青，省钱、省心
- ◆ 2分钟内即可加满油箱，无需人工倒油
- ◆ 消除压路机行业人工抹油的安全隐患

#### 液压轮边制动技术

- ◆ 全液压制动可在发动机熄火，杜绝安全隐患
- ◆ 制动距离与行业平均距离相比短 50%，彻底消除制动安全隐患
- ◆ 驱动桥常闭驻车制动，停机就制动，不需拉手刹

### EXCEPTIONAL COMPACTION PERFORMANCE

- ◆ Meeting the demands of compaction for asphalt road and cement stabilized base

# TECHNICAL PARAMETER 技术参数

## SPR260C-8S 轮胎压路机技术参数

Technical Parameter of SPR260C-8S Pneumatic Roller

Model		SPR260C-8S
压实性能参数 Compaction	最大整机质量 Max. Operating Weight(kg)	26000
	最小整机质量 Min. Operating Weight(kg)	11000
	接地比压 Ground Pressure(kPa)	200~520
	单胎载荷 Single Tyre Load(t)	2.88
	充气压力 Tyre Inflation Pressure(kPa)	200~800
	压实宽度 Compaction Width(mm)	2368
	重叠宽度 Overlap(mm)	63
机动性能参数 Maneuver Ability	工作速度 Working Speed(km/h)	0~5.5
	行驶速度 Travel Speed(km/h)	0~8
	转向角度 Steering Angle(°)	0~10
	理论爬坡能力 Gradeability	0~14
	摇摆距 Swing Distance(mm)	30
	离地间隙 Ground Clearance(mm)	25%
	轴距 Wheelbase(mm)	50
发动机 Engine	最小转弯外直径 Min. Turning Outside Diameter (mm)	350
	供应商 Brand	WEICHAI
	型 Model	WP6G190E301
	排放 Emission	CHINA III
容量参数 Capacity	功率(kW)	140
	蓄电池 Accumulator(V×Ah)	24×120
	水箱 Water Tank(L)	500
	燃油箱 Fuel Tank(L)	200
	液压油箱 Hydraulic Oil Tank(L)	100

## 轮胎压路机 SPR260C-8S 标配选配表

Pneumatic Rollers SPR260C-8S Standard and Optional Configurations

配置类型 Config	配置名称 Systems	物料名称 Description	数量 / 台 Quantity	详细说明 Details	备注 Remarks
标准配置 Standard Configuration	主机 Main Machine	SPR260C-8S 轮胎压路机标配	1	1.Engine 发动机 2.Travel Pump 行驶泵 3.Travel Motor 行驶马达 4.Transaxle 驱动桥 5. Cab 驾驶室 6. Front Covering Part 前覆盖件 7. Front Wheel Assembly 前轮总成 8. Rear Wheel Assembly 后轮总成 9. Electrical System 电气系统 10.Frame Assembly 车架总成 11. Water Spraying System 洒水系统	
		SPR260C-8S Pneumatic Tyre Rollers, Standard			
可选配置 Optional Configuration	空调 Air Conditioner	空调系统 Air Condition System	1	配备驾驶室以便于在风沙大, 极端温度条件下工作 Work in windy, sandy, and extreme temperature conditions	可选 Optional
	倒车可视 Rear Vision System	倒车可视 Rear Vision System	1	适用于不开阔的路况, 例如居民区 Work in confined areas such as residential areas	可选 Optional
	集中充气 & 自动喷油 Centralized Inflation and Auto-Oil-spraying System	集中充气 & 自动喷油 Centralized Inflation and Auto-Oil-spraying System	1	高海拔路况 High-grade road works	可选 Optional

## 轮胎压路机 SPR260C-8S 尺寸参数

Dimensions of SPR260C-8S Pneumatic Roller

Size Code	SPR260C-8S
A (mm)	4170
B (mm)	2368
H (mm)	3280
K (mm)	350
L (mm)	5435
W (mm)	2279

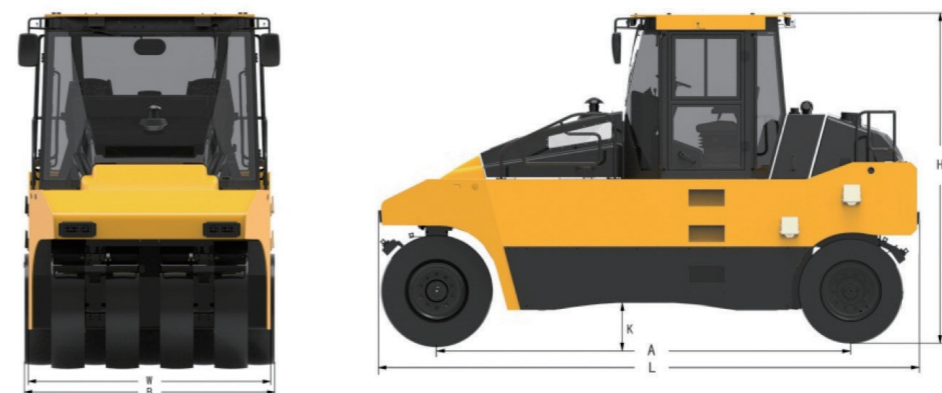

SANY HEAVY INDUSTRY CO., LTD.

SANY Industry Town, Changsha Economic and Technological Development Zone, Hunan Province, China

Service Line: +86 4006 098 318 E-mail: crd@sany.com.cn

**SANY**<sup>®</sup>  
QUALITY CHANGES THE WORLD.